

HP11 SERIES HEAT PUMP WITH "L7" TWO SPEED COMPRESSOR

I - INTRODUCTION

A few HP11-511-1 units were manufactured as deviations in 1978, but the standard production units were not released until 1979.

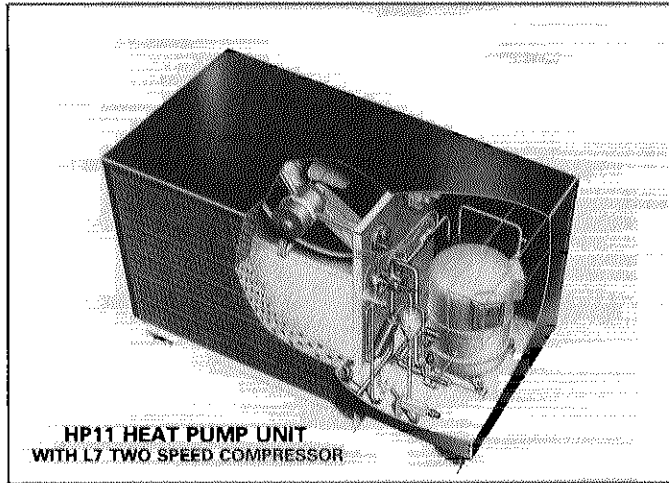

FIGURE 1

The HP11 features the Lennox "L7" two speed compressor which shifts speeds to match load requirements. At low speed it cuts energy consumption by nearly 50% over a single speed compressor. Figure 1 shows a cutaway of the unit.

The HP11 can be applied to installations where the cooling gain is matched to low speed capacity and the high speed to heat pump operation. During the cooling season, the heat transfer surfaces are oversized resulting in increased capacity and efficiency. During the heating season the HP11 can switch to high speed for increased heat pump capacity. For optimum energy efficiency in this application, do not connect thermostat lead identified as "M2".

The following table lists the units to available tonnage. Duct work must be sized to high speed air requirements.

Unit	Tonnage At Low Speed	Tonnage At High Speed
HP11-311-511V	2-1/2	4
HP11-413/653V	3	5
HP11-411/651V	3	5

II - UNIT INFORMATION

A - Specifications

Model No.		HP11-311/511V	HP11-411/651V HP11-413/653V
Outdoor Coil	Net face area (sq. ft.)	7.92	7.92
	Tube diam. (in.) & No. of rows	1/2 — 3	1/2 — 4
	Fins per inch	10	10
Outdoor Fan	Diameter (in.) & No. of blades	26 — 4	26 — 4
	Motor hp	1/2	1/2
	Cfm (factory setting)	4830	4500
	Rpm (factory setting)	830	830
	Watts (factory setting)	605	650
Refrigerant-22 (charge furnished)		14 lbs. 0 oz.	17 lbs. 3 oz.
Liquid line connection		3/8 (compression)	1/2 (sweat)
Vapor line connection		7/8 (compression)	1-1/8 (sweat)
Shipping weight (lbs.) & No. of packages		412 — 1	428 — 1

B - Electrical Data

Model Number		HP11-311/511V	HP11-411/651V	HP11-413/653V
Line voltage data		230v/60hz/1ph.	230v/60hz/1 ph.	230v/60hz/3 ph.
Compressor	Rated load amps	23.8	31.1	19.0
	Power factor	0.96	0.95	0.9
	Locked rotor amps	124.0	163.0	144.0
Outdoor Coil Fan Motor	Full load amps	3.2	3.2	3.2
	Locked rotor amps	5.6	5.6	5.6
Recommended maximum fuse size (amps)		55.0	70.0	45.0
*Minimum circuit ampacity		33.0	42.1	27.0

*Refer to National Electrical Code manual to determine wire, fuse and disconnect size requirements.

NOTE — Extremes of operating range are plus and minus 10% of line voltage.

C - Pressure Curves

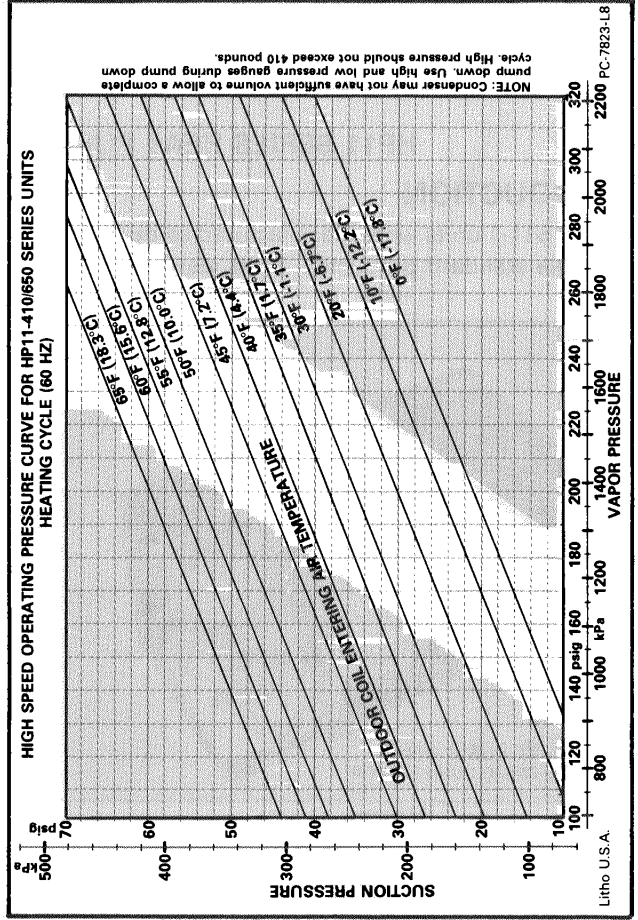
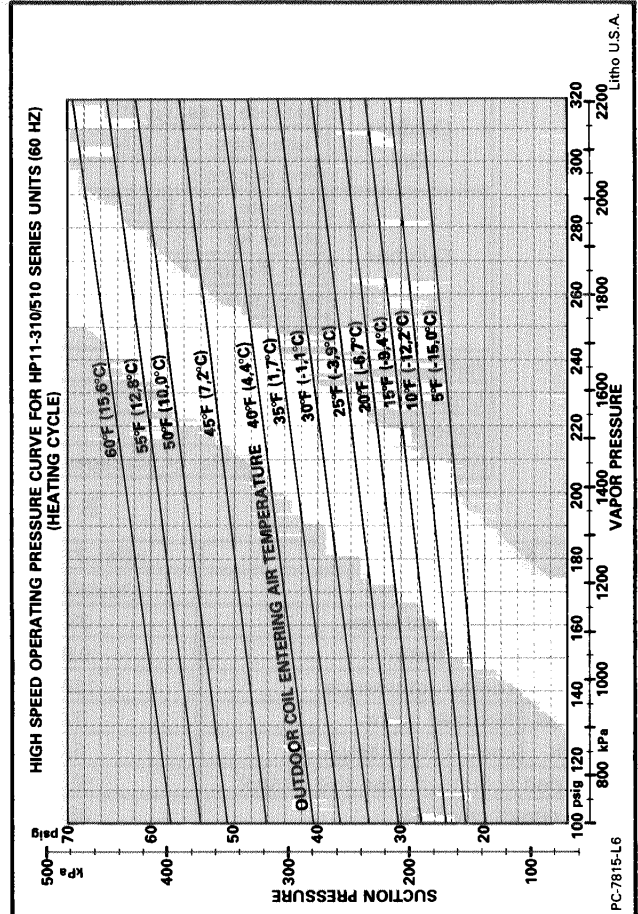
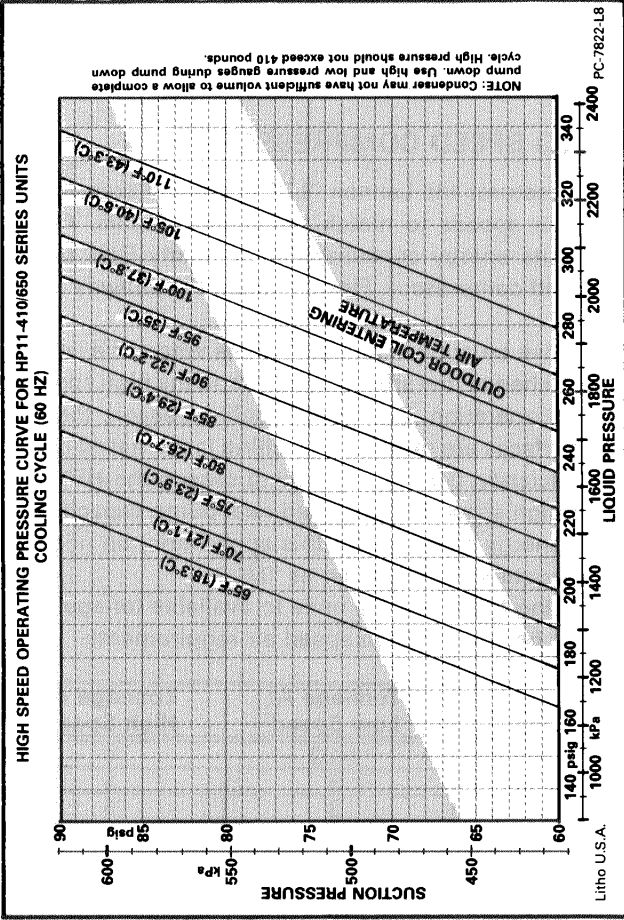
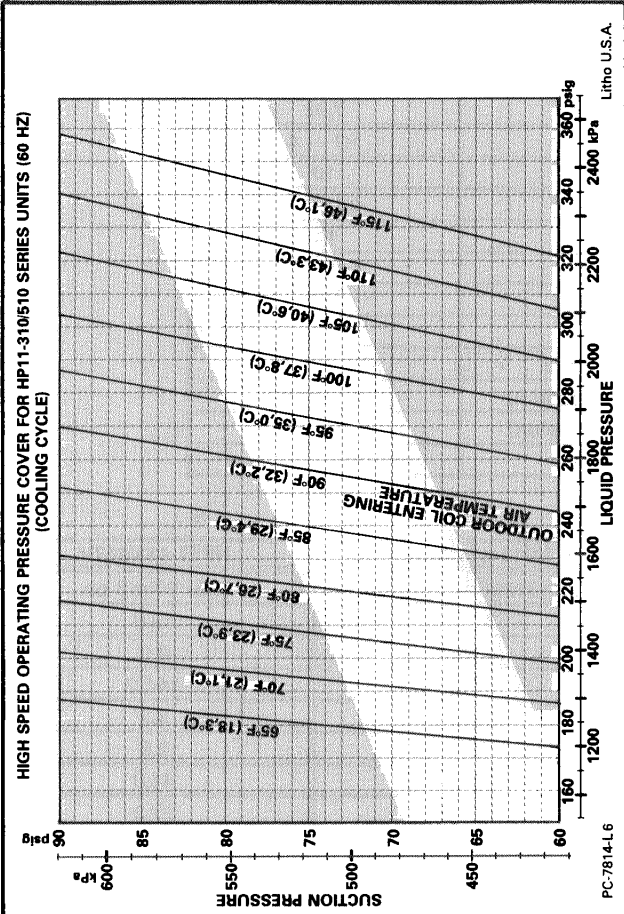

D - Dimensions

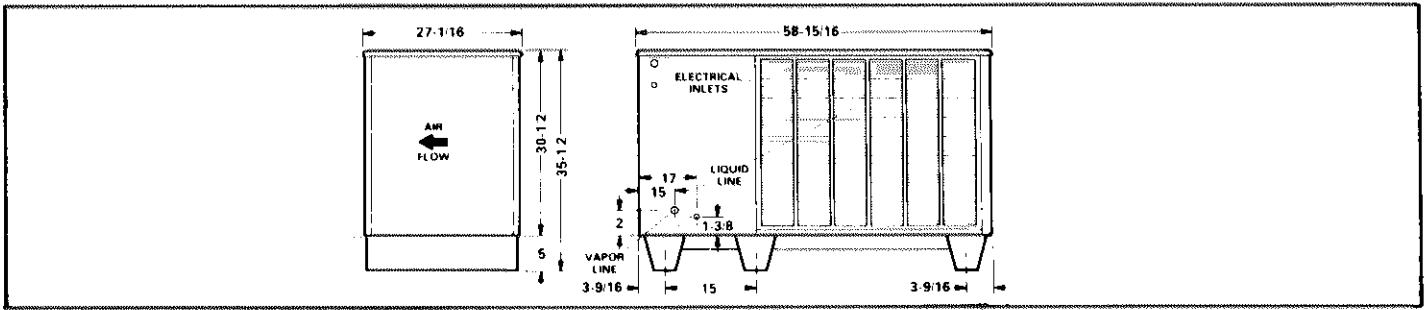

E - Heating Performance Charts

HP11-311/511V HEATING PERFORMANCE
at 1800 cfm Indoor Coil Air Volume
(CBP10-51)

*Outdoor Temperature (Degrees F)	Comp. Motor Watts Input	Total Output (Btuh)
65	4440	62,500
60	4255	58,900
55	4090	55,300
50	3895	51,800
45	3720	48,200
40	3525	44,600
35	3330	41,400
30	3155	38,400
25	3000	35,200
20	2815	32,600
15	2630	29,600
10	2435	26,000
5	2245	22,600
0	2060	19,000
-5	1785	15,000
-10	1690	12,000
-15	1595	9,000
-20	1505	7,000

HP11-311/511V HEATING PERFORMANCE
at 1800 cfm Indoor Coil Air Volume
(CBPH10-645/51 & CPH10-645)

*Outdoor Temperature (Degrees F)	Comp. Motor Watts Input	Total Output (Btuh)
65	4475	60,000
60	4290	56,500
55	4125	53,100
50	3926	49,700
45	3750	46,300
40	3555	42,800
35	3355	39,700
30	3180	36,900
25	3025	33,800
20	2840	31,300
15	2650	28,400
10	2455	25,000
5	2265	21,700
0	2075	18,200
-5	1800	14,400
-10	1705	11,500
-15	1610	8,700
-20	1515	6,800

HP11-311/511V HEATING PERFORMANCE
at 1800 cfm Indoor Coil Air Volume
(C12-840 & CR12-840)

*Outdoor Temperature (Degrees F)	Comp. Motor Watts Input	Total Output (Btuh)
65	4610	62,200
60	4415	58,600
55	4245	55,000
50	4020	50,500
45	3840	47,000
40	3640	43,500
35	3435	40,400
30	3255	37,400
25	3075	34,300
20	2885	31,800
15	2695	28,800
10	2485	25,400
5	2290	22,100
0	2100	18,600
-5	1820	14,700
-10	1705	11,700
-15	1610	8,800
-20	1520	6,900

HP11-410-650V HEATING PERFORMANCE
at 2250 cfm Indoor Coil Air Volume
(C12-1120 & CR12-1120)

*Outdoor Temperature (Degrees F)	Compressor Motor Watts Input	Total Output (Btuh)
65	5685	72,400
60	5445	69,600
55	5205	66,700
50	4985	63,600
45	4765	59,600
40	4550	55,700
35	4340	52,200
30	4115	48,700
25	3915	45,700
20	3690	42,500
15	3505	36,700
10	3305	34,600
5	3090	30,900
0	2845	27,300
-5	2640	23,800
-10	2400	19,900
-15	2150	15,900
-20	1910	12,200

*Outdoor temperature at 70% relative humidity.
Indoor temperature at 70°.

F - Approved Match-ups

All major components must be matched according to Lennox recommendations for the compressor to be covered under warranty. A misapplied system will cause erratic operation and can result in early compressor failure. The heat pump selector in the introduction to heat pumps lists the approved match-ups.

Line sets are available for HP11-310/510, but must be field fabricated for HP11-410/650. HP11-310/510 use compression fittings while HP11-410/650 use sweat.

G - Typical Field Wiring Diagram

High voltage leads provided in make-up area of control box for connection to power supply. Refer to Figure 2. Ground lug provided in high voltage make-up area.

Note on unit wire sizing & fuse selection - Minimum circuit ampacity and maximum fuse size are listed on the unit rating plate and in the Engineering Handbook. The unit supply wire size must be obtained from the appropriate Table 310 in the National Electric Code Book. Lennox recommends using the Maximum Fuse Size listed to prevent nuisance trippouts.

Low voltage connections are made at the terminal strip located in the low voltage junction box.

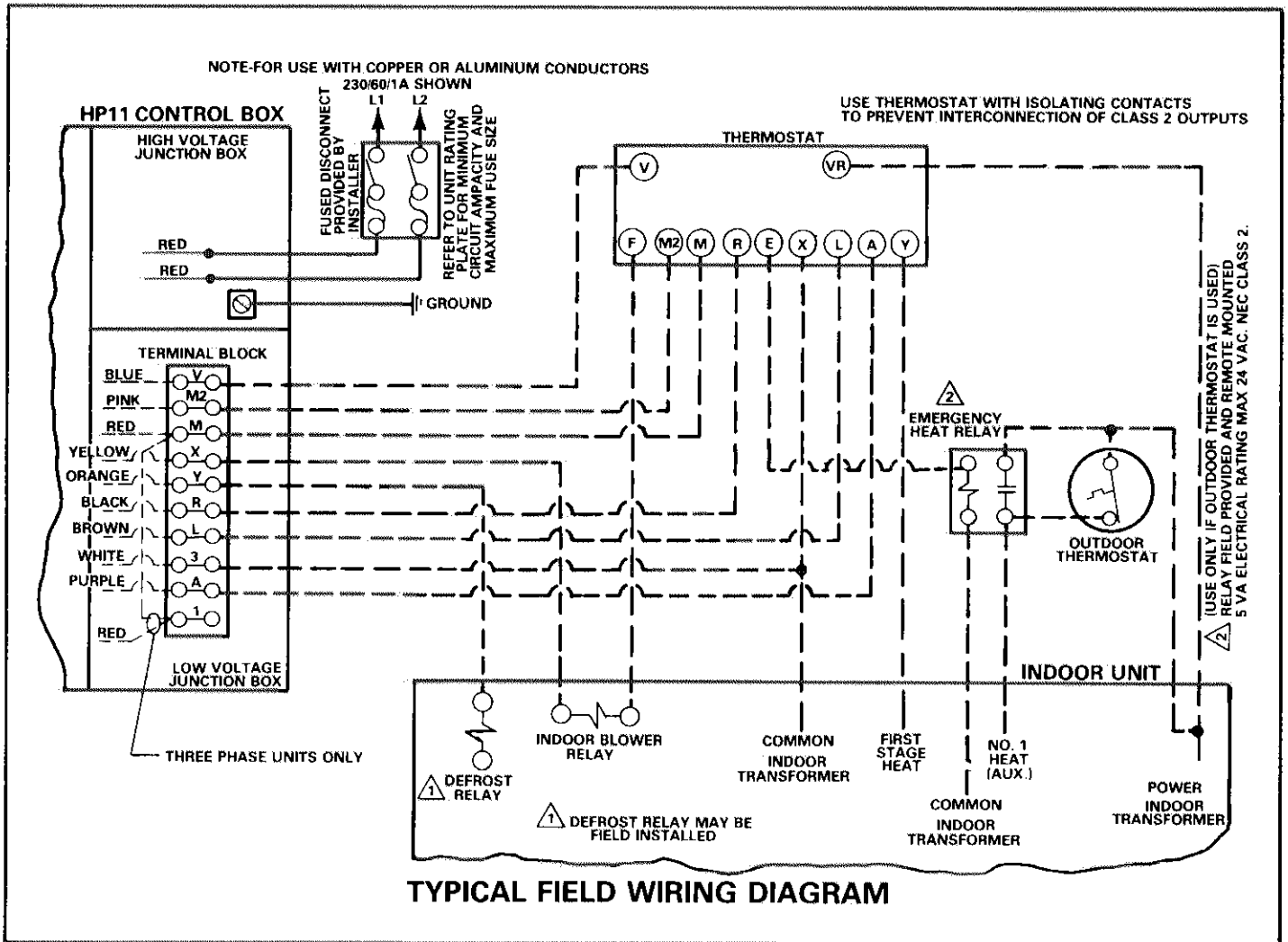

FIGURE 2

H - Optional Latent Load Discriminator (LB-34857BA)

The optional Latent Load Discriminator Kit controls the speed of the indoor blower motor to provide maximum dehumidification when needed. The Kit has a dehumidistat

which switches blower to low speed at high humidity conditions for latent cooling. During low humidity conditions, blower operates at high speed for maximum sensible cooling.

Figure 3 shows the field wiring for the Latent Load Discriminator.

Cooling Cycle - With dehumidistat contacts closed (high humidity), the Dehumidistat Relay is energized to consequently de-energize the Latent Load Relay and slow the motor to minimum blower speed. With dehumidistat contacts open (low humidity), the Latent Load Relay remains

energized and the blower motor remains on high speed.
Heating Cycle - Because there is no voltage through "R", the Latent Load Relay is de-energized and the motor goes to minimum blower speed.

Defrost Cycle - During the defrost cycle, the indoor blower motor will change speed according to the de-humidistat position just as in the cooling cycle.

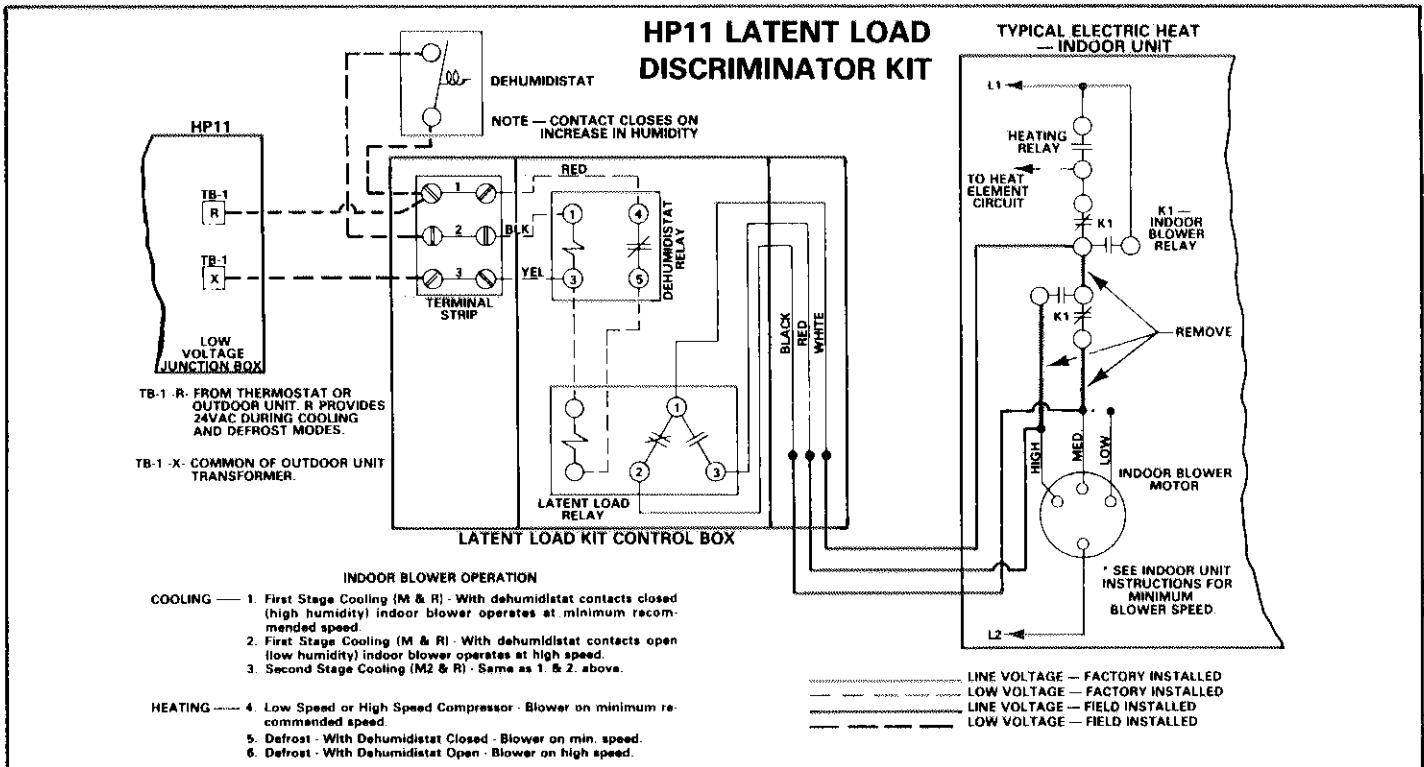

FIGURE 3

III - REFRIGERANT SYSTEM

The vapor line and liquid line service valves and gauge port connections are located inside cabinet as shown in Figure 4. Figures 5 and 6 show the gauge manifold connections for both the cooling and heating cycles. They also show the refrigerant flow.

It is very critical not to overcharge a heat pump. It is desirable to charge the system in the cooling cycle if weather conditions permit. However, if the unit must be charged in the

heating cycle, the charge should be rechecked in the cooling cycle when outdoor conditions permit. The HP11 must run at high speed when checking the charge with the normal operating pressure curve.

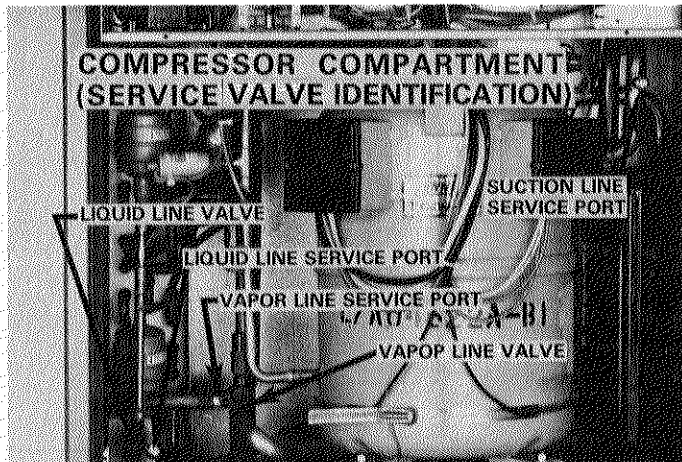

FIGURE 4

IV - HP11 COMPONENTS

Figure 7 shows an exploded view of the HP11 unit.

A - Control Box (Figure 8)

1 - Protective Module

The module wires to sensors buried in the compressor through S1 and S2. P1 and P2 power the module. They connect directly to transformer. Power out of module to compressor control circuit is through K1 and K2. Should the sensors detect excessive heat, the module switches off the compressor control circuit. The module checkout is discussed later.

2 - Current Limiting Device (1Ø units only) (RT-2)

The current limiting device is a NTC thermistor (negative temperature coefficient). Which means that an increase in temperature equals a decrease in resistance as the compressor slows to a stop at the end of a cycle. This device absorbs any momentary power surge from the run capacitor and thus prevents the potential relay contacts from sticking. Resistance at 25°C equals 5 ohms ± 10%.

HP11 COOLING CYCLE (SHOWING GAUGE MANIFOLD CONNECTIONS)

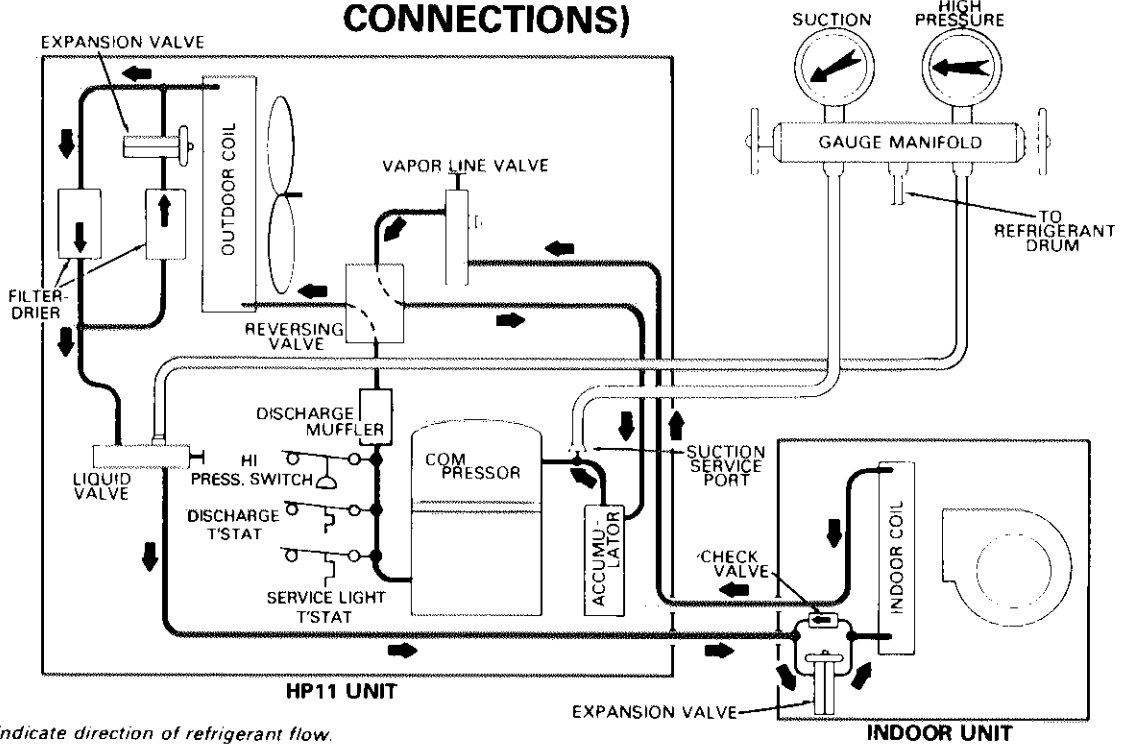

FIGURE 5

HP11 HEATING CYCLE (SHOWING GAUGE MANIFOLD CONNECTIONS)

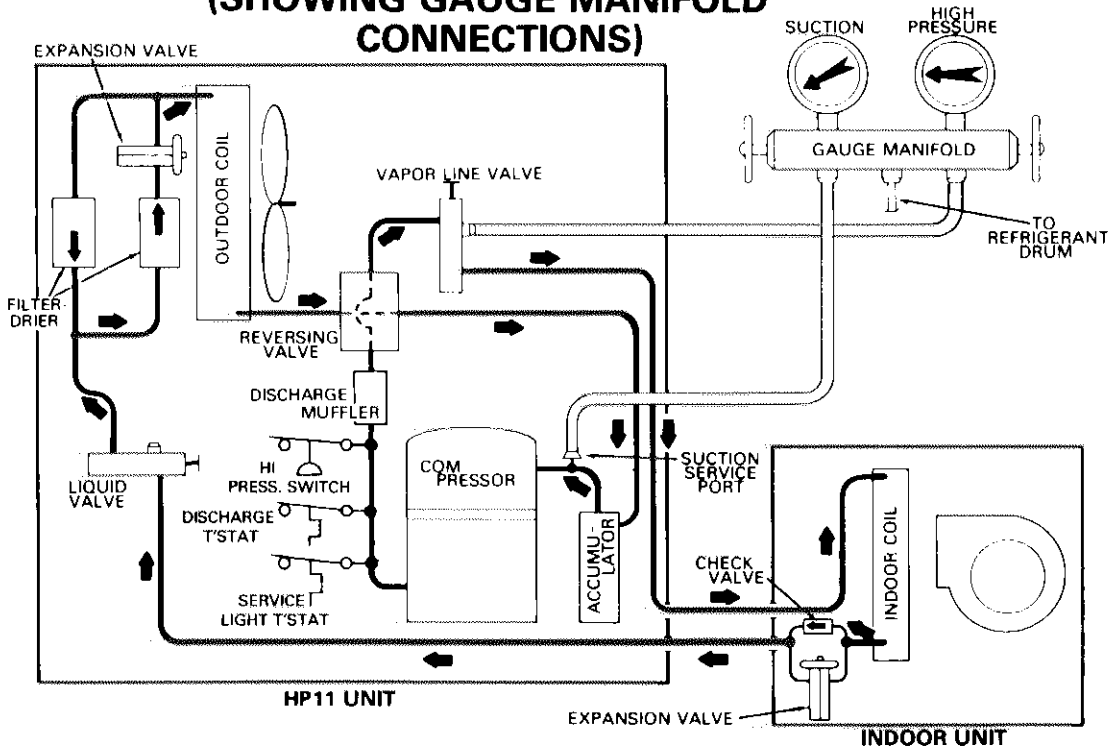
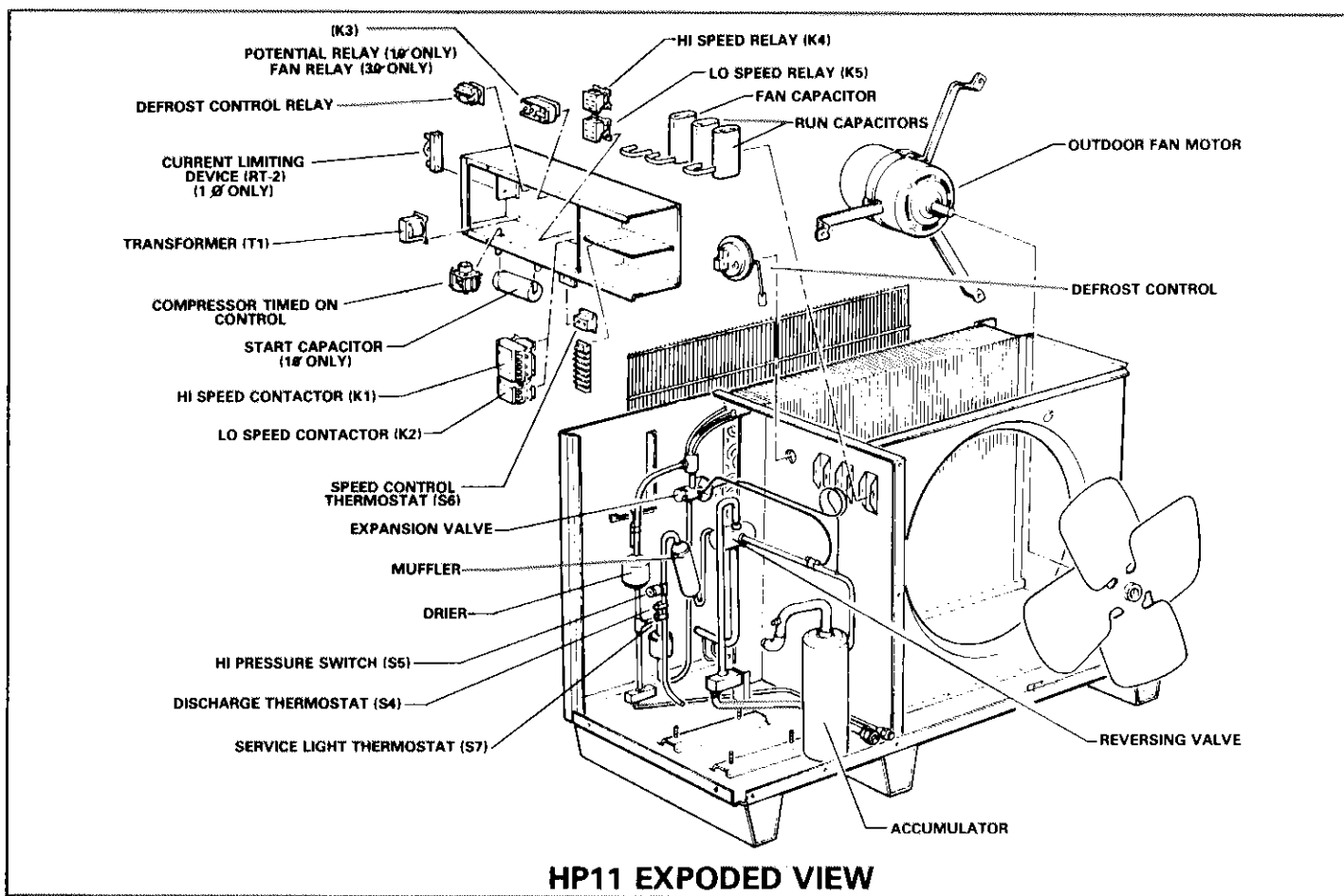
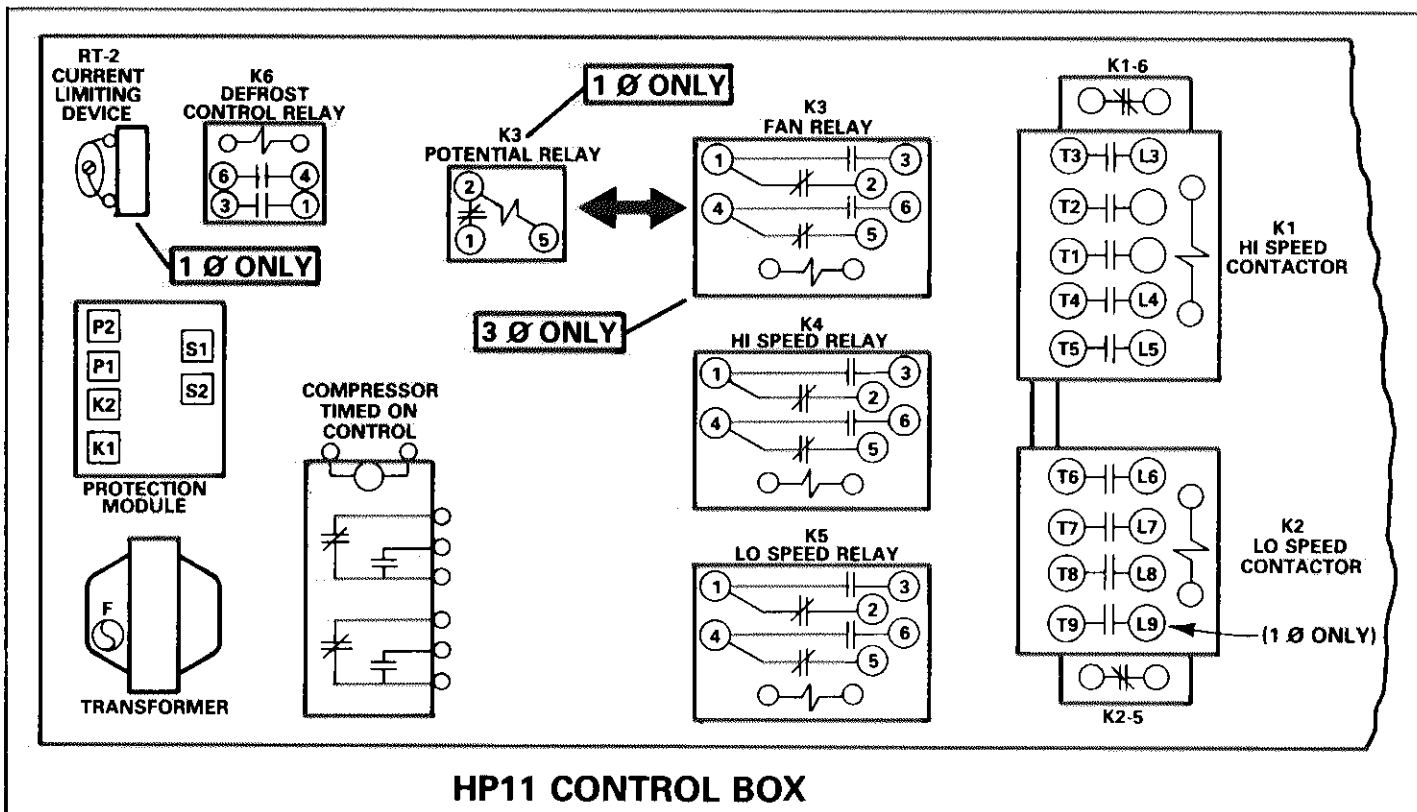

FIGURE 6



HP11 EXPLODED VIEW

FIGURE 7



HP11 CONTROL BOX

FIGURE 8

3 - Transformer

208/230V primary / 24V secondary - 70VA
3.2 Amp (type C) fuse on secondary

4 - Compressor Timed On Control

The compressor timed on control prevents compressor short cycling and also allows time for suction and head pressures to equalize, permitting the compressor to start in an unloaded condition. This is a cam operated switching device that utilizes a 3 watt, 24 volt motor. The motor drives with clockwise rotation to operate two snap action switches. These switches are single pole, double throw and operate 180° opposite from one another.

This control provides a positive stop between speed changes on compressor. This delay varies from 3 minutes on early production units to 1 minute on current production.

This device has a manual reset screw located in the compressor compartment. See Figure 9. Rotating the screw clockwise resets the control. Remember that the compressor must come to a complete stop between speed changes. If you rotate the reset control, be sure to stop each time the compressor changes speed. Let compressor come to a complete dead stop before advancing to the next position. Failure to do this can damage the compressor.

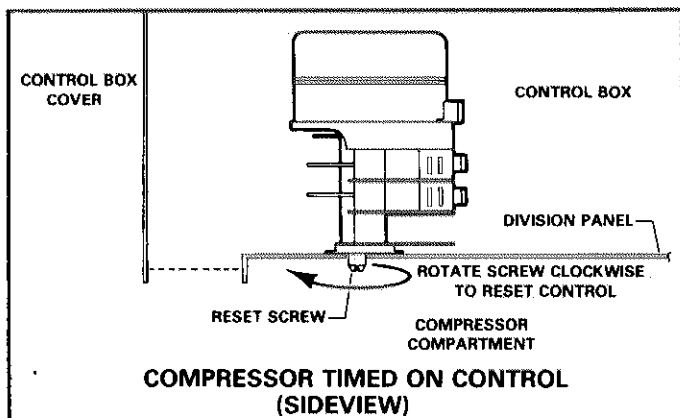

FIGURE 9

5 - Defrost Control Relay

Is a two-pole single-throw with normally open contacts and 208/240V coil.

6 - Potential Relay (1Ø only) (K3)

Used in conjunction with start capacitors to bring compressor to operating speed.

Approximate pick-up volts (cold) Max - 275V/Min - 245V

Approximate dropout volts (cold) Max - 125V/Min - 70V

7 - Fan Relay (3Ø only) (K3)

Used to control fan motor and crankcase heater.

8 - Control Relays (K4 & K5)

Used in 24 volt control circuit for low and high speed compressor operation.

9 - Compressor Contactor Hi Speed (K1) & Lo Speed (K2)

The HS11 uses a special contactor. It has two coils, one with four poles and one with five poles. Also each is equipped with a normally closed auxiliary contact. These two contactors are mechanically interlocked so that only

one can be energized at any given time. This prevents the unit from being powered at both high and low speeds at the same time.

B - Compressor Compartment (Figure 10)

1 - High Pressure Switch (S5)

Switch is mounted in discharge line. This switch has a cutout pressure of 410 psig; reset 180 psig - Manual Reset.

2 - Discharge Temperature Limit Switch (S4)

The discharge temperature limit switch is installed on the discharge line. It shuts off the compressor if discharge temperature exceeds 260°F. The switch must be manually reset when discharge temperature drops to 225°F or below.

3 - Service Light Thermostat (S7)

The service light thermostat is used in conjunction with the room thermostat. It monitors discharge temperature and closes on a temperature fall (110°F in - 130°F out). If the room thermostat is in a heating demand with the second stage bulb made and S7 closes, a red service light comes on at room thermostat. This service light may briefly come on during a compressor start-up.

4 - Speed Control Thermostat (S6)

During the heating mode, this thermostat determines compressor speed. At temperatures below 45°F the compressor switches to high speed to provide maximum heating capacity. At temperatures above set point the compressor runs at low speed. There is a 5° differential between cut-in and cut-out temperatures.

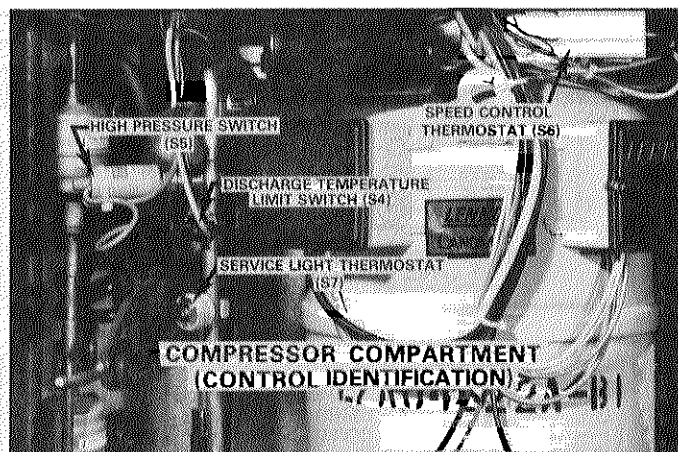

FIGURE 10

C - Outdoor Coil Compartment (Figure 11)

The high pressure monitor portion of the defrost control is located between the outdoor coil and outdoor fan. The ambient compensating thermistor is used in conjunction with the room thermostat. It varies heat anticipator resistance as the ambient temperature changes. The outdoor coil is circuited with the refrigerant flow from bottom to top during a defrost cycle. This provides more positive defrost and better condensate run-off.

The HP11 uses a blow-through coil with horizontal discharge. The fan motor is prelubricated for an extended period of

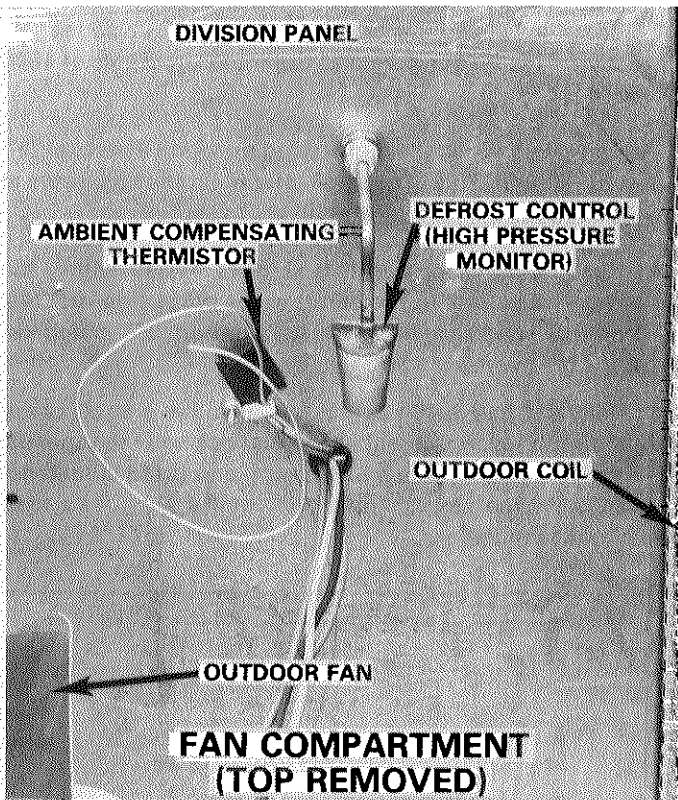

FIGURE 11

operation. Some motors employ sealed ball bearings which need no further lubrication. Check motor for lubrication requirements. For fan service access remove top of unit and then remove the bolts securing fan assembly. Figure 12 illustrates the condenser fan and motor assemblies.

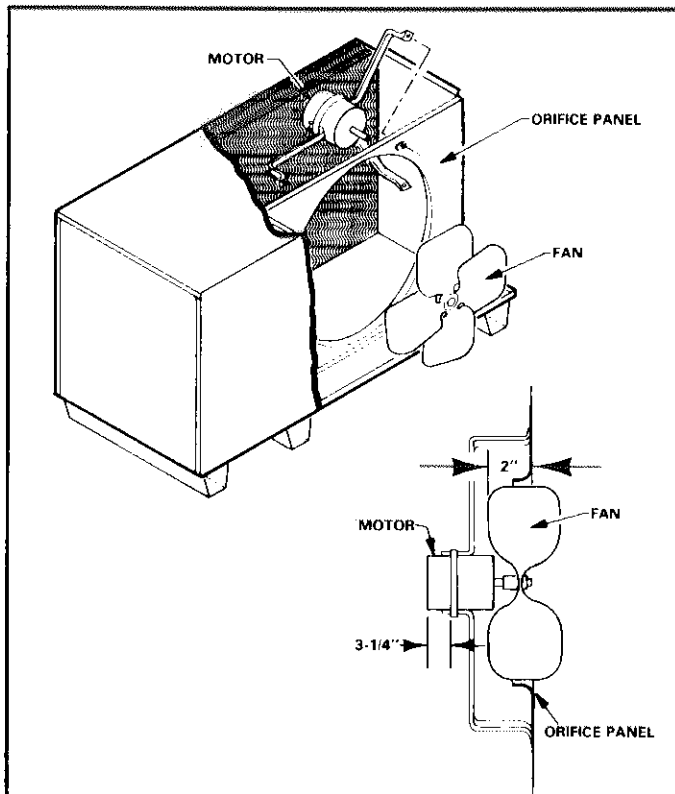

FIGURE 12

D - Room Thermostat

HP11 uses a two stage cool - two stage heat thermostat with ambient compensating thermistor and emergency heat sub-base. The ambient compensating thermistor cuts down thermostat droop to improve the operating characteristics of the system. The thermistor is located in the outdoor fan compartment.

Thermostat is equipped with two indicator lights. The red service light warns the homeowner that the compressor is not operating properly and the heat pump is in need of service. As the HP11 is cycled "on" by a heating demand, this light may come on briefly until the compressor reaches its normal operating conditions. The homeowner should be made aware that this short intermittent lighting is normal. The amber light comes on whenever the thermostat is placed into emergency heat. It reminds the homeowner that he is not getting the benefit of his heat pump and that he is using expensive electric heat. Figure 13 illustrates HP11 thermostat.

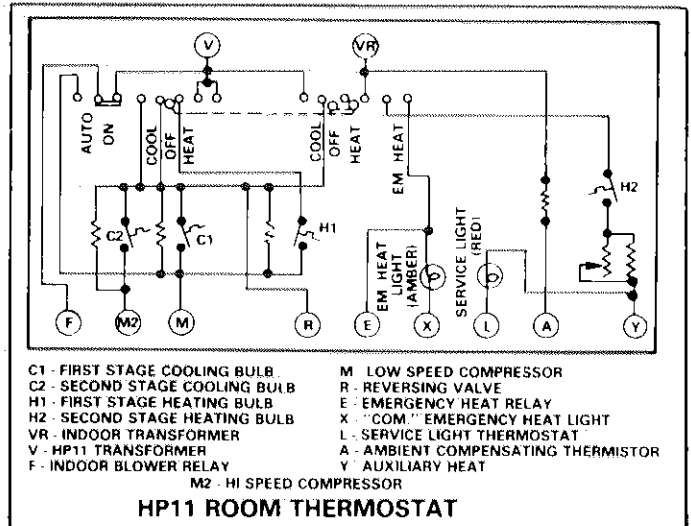

FIGURE 13

E - "L7" Compressor (Figure 14)

The speed of a motor operating at 60 cycles current is 7,200 divided by the number of poles. There are always an even set

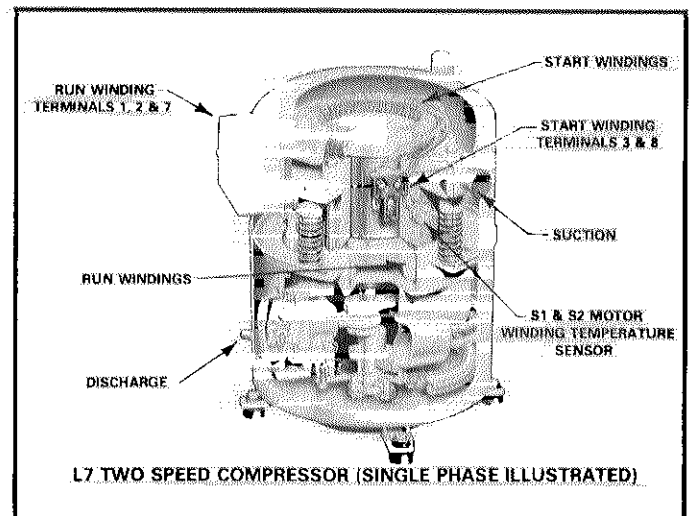

FIGURE 14

of poles such as 2, 4, 6 etc. Figures 15 and 16 show the motor windings for both single phase and three phase "L7" compressors.

1 - Single Phase (Figure 15)

During low speed two run windings are in series between terminals 1 and 7. This is four pole and the motor operates at 1800 RPM. There are also four start windings in series between terminals 1 and 8 which are used in conjunction with the potential relay and start capacitor to bring the motor up to speed.

During high speed two parallel run windings are used (terminals 2-1 and 2-7). This is two pole and the motor operates at 3,600 RPM. There are also two start windings in series between terminals 1 and 3 which are used in conjunction with the potential relay and start capacitor to bring the motor up to speed.

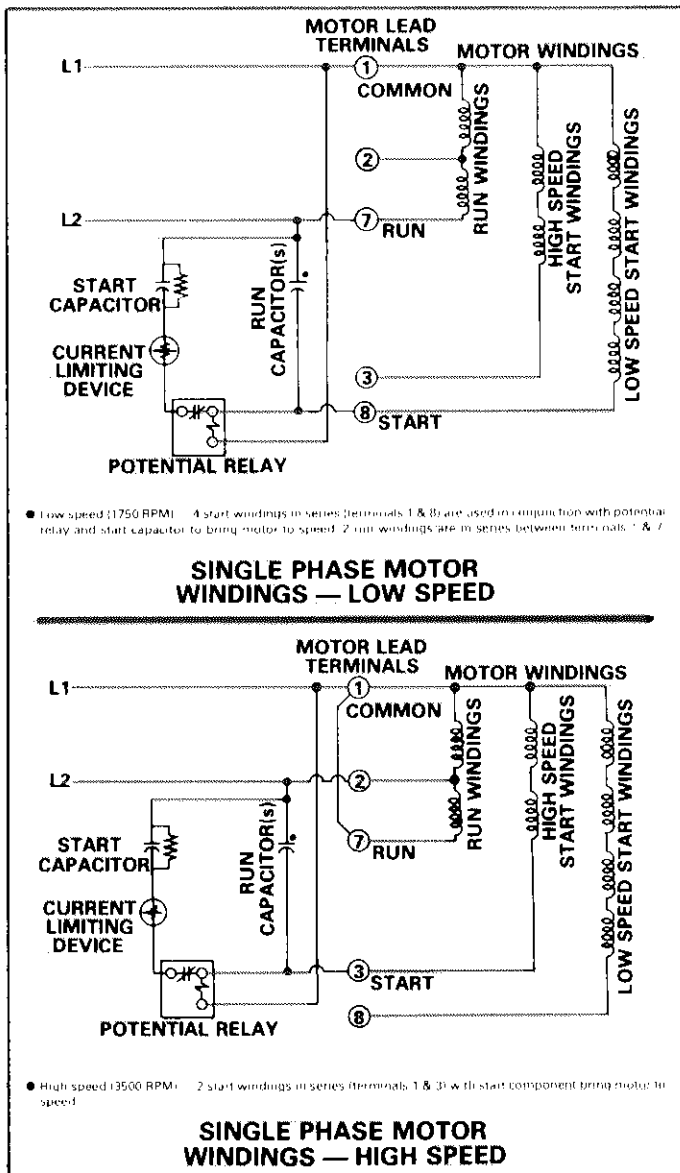

FIGURE 15

2 - Three Phase (Figure 16)

During low speed the motor windings form a series "Y" circuit. This is four pole and the motor operates at 1800 RPM.

During high speed the motor windings form a parallel "Y" motor circuit. This is two pole and the motor operates at 3,600 RPM.

The "L7" compressor has two sensors buried within the windings which link to the compressor protection module. An external crankcase heater is standard on "L7" compressors.

The high and low speed contactors each have an auxiliary contact which serves as a positive interlock between speeds. This prevents both speeds from being energized simultaneously. The compressor "timed-on" control provides a time delay between speeds.

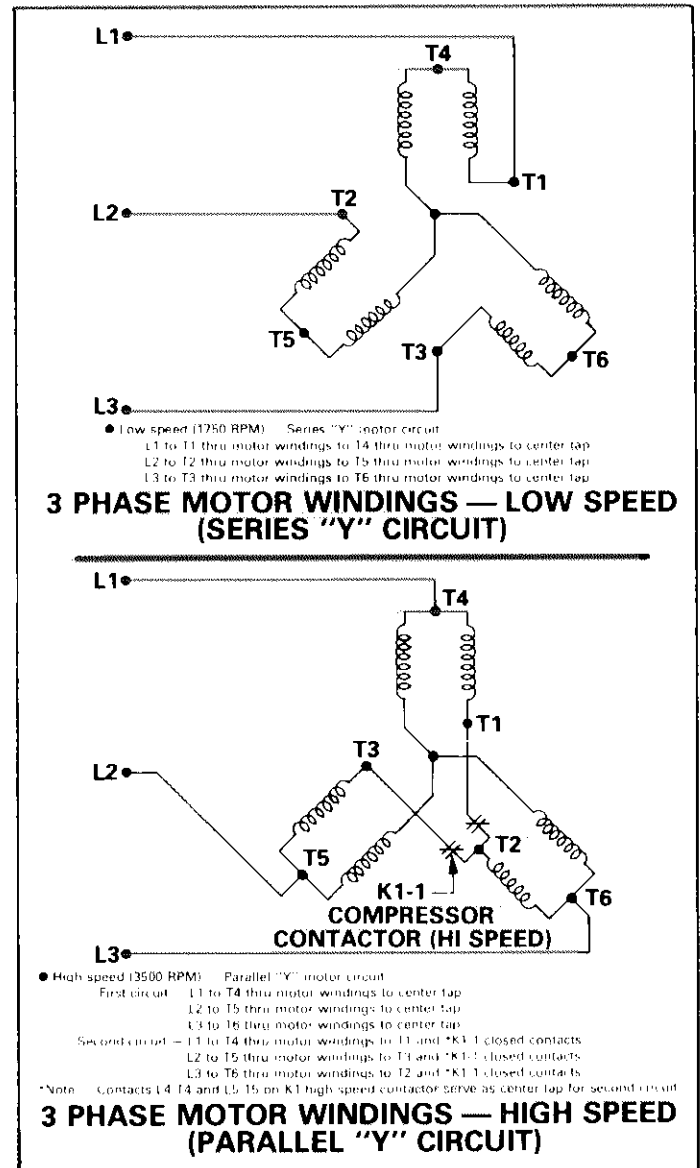

FIGURE 16

F - Defrost Control Figure 17

Robertshaw defrost control is pressure initiated and temperature terminated. The high pressure monitor portion of the defrost control is located in the outdoor fan section between the coil and fan. Low pressure is monitored from the compressor compartment. The sensing bulb is clamped to the liquid line.

The control will initiate the defrost cycle at a pressure difference across the outdoor coil at approximately 0.5" WC. The defrost cycle will terminate when the temperature sensor clamped to the liquid line on the outdoor coil reaches 65°F.

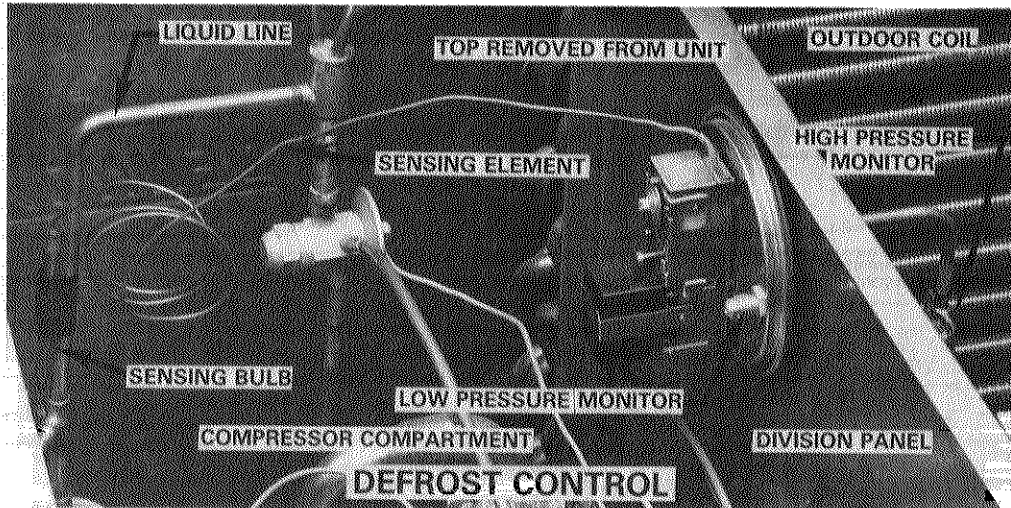

FIGURE 17

TEXAS INSTRUMENTS SOLID STATE COMPRESSOR PROTECTION

UNIT		TEMPERATURE
3 PHASE UNITS		185°F (85°C)
SINGLE PHASE UNITS	MAIN WINDINGS	176°F (80°C)
	START WINDINGS	221°F (105°C)

- 1 - Provide a cooling demand and check the voltage at K1 and K2. Power (24 volts) indicates that the module is O.K. and there is another component open in the control circuit.
- 2 - Check for 24 volts at P1 & P2. If there is no voltage, check the unit transformer and power supply to unit.
- 3 - Checking Thermal Sensors
 - a - Remove thermal sensor leads from S1 and S2 terminals and check the resistance.
 - b - The trip setting ranges from 16K to 24K.
 - c - The reset setting ranges from 5.5K to 6.9K.
 - d - If an open circuit is indicated the compressor must be replaced.
 - e - If a shorted circuit is indicated, the compressor must be replaced.
- 4 - Checking Module (Detail "A")
 - a - Remove thermal sensor leads and place a 25K resistor across terminals. There should be no voltage at K1 and K2 terminals.
 - b - Substitute a 5K resistor and recheck K1 and K2 terminals. The module should reset and provide 24 volts.
 - c - If module doesn't function properly, replace.

FIGURE 18

VI - SCHEMATIC WIRING DIAGRAM OPERATING SEQUENCE

Each of the following steps within this section are labeled in the corresponding diagram.

A - COOLING MODE (LOW SPEED)

24V Control Circuit Cooling Low Speed (Figure 19)

- 1 - Thermostat powered through V terminal.
- 2 - The reversing valve L1 is energized through terminal "R".
- 3 - A cooling demand closes C1 and energizes Low Speed Relay (K5) through "M" and terminals 2 & 1 of Outdoor Ambient Speed Control Thermostat (S6).
- Note - At ambient temperatures below 45°F, terminals 2 & 3 close to energize the High Speed Relay (K5).
- 4 - 24 volts is simultaneously fed through the Protection

Module, Discharge Temperature Limit Switch (S4) and High Pressure Switch (S5).

- 5 - Timer motor is energized through the N.C. timer switch, N.O. K5-1 contacts (energized at step 2), and N.C. K4-1 contacts.
- 6 - After a time period, the Compressor Timed-On Control contact will switch position breaking power to the timer motor.
- 7 - Low Speed Contactor (K2) is energized through N.O. K5-2 contacts and the N.C. K1-6 compressor interlock.
- 8 - With K2 energized, the compressor interlock contacts K2-5 open to make sure the High Speed Contactor (K1) can not be energized.
- 9 - On 3 ϕ units the Fan Relay (K3) is also energized by first stage cooling through terminal "M" and "1".

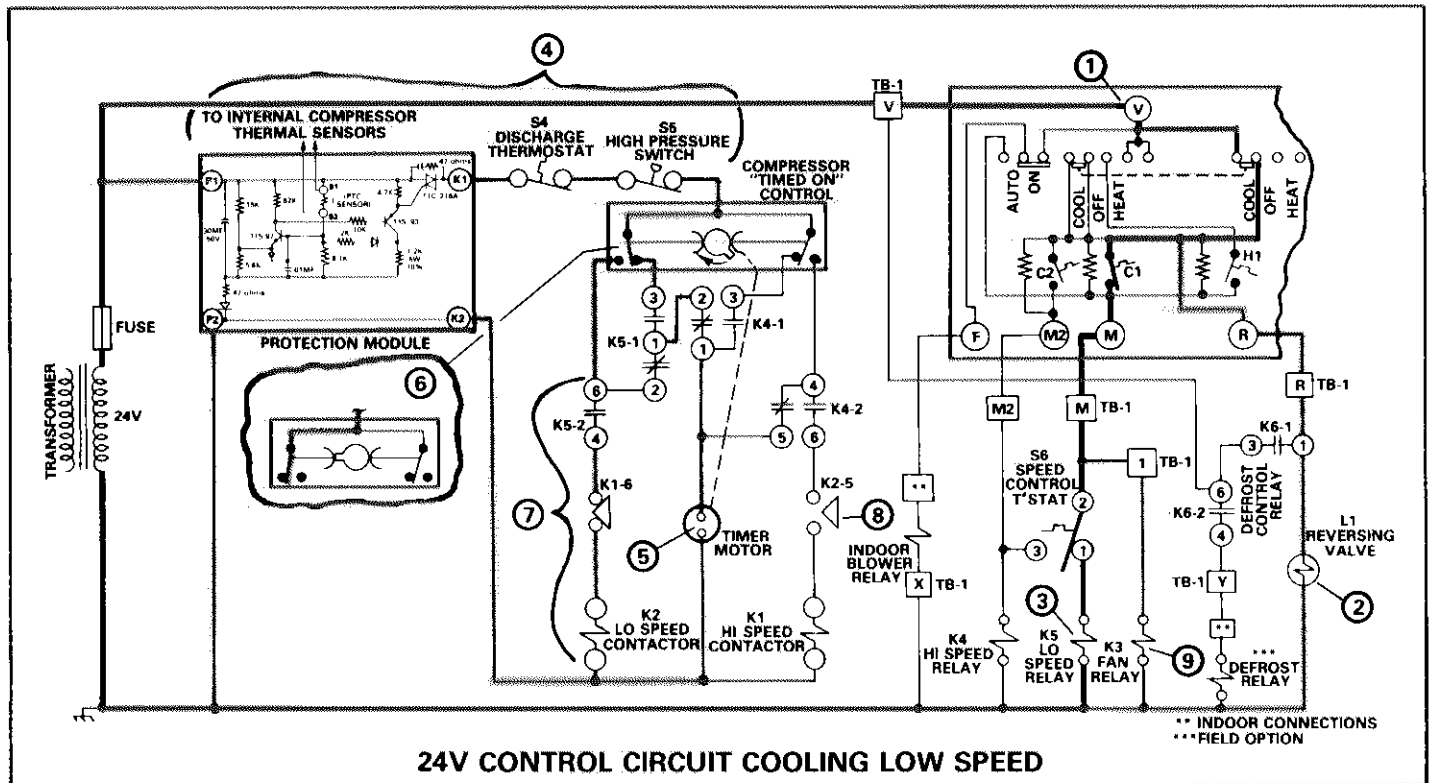

FIGURE 19

3 ϕ Compressor Circuit - Low Speed (Figure 20)

- 1 - K2-1 Low Speed Contactor is energized by the low voltage circuit.
- 2 - Compressor terminals 1, 2 and 3 are energized thru contacts 6, 7 and 8 to form a series "Y" motor winding circuit.
- 3 - The Fan Relay (K3) closes its contacts after being energized by the low voltage control circuit. This de-energizes the crankcase heater.
- 4 - With K3-1 and K3-2 contacts closed the outdoor fan motor is energized through the normally closed terminals (2 & 3) of Defrost Control Switch.

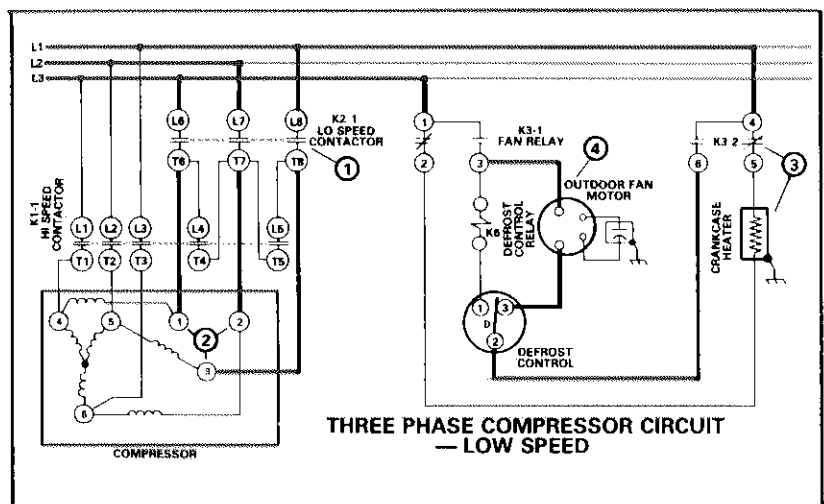

FIGURE 20

1Ø Compressor Circuit - Low Speed (Figure 21)

- 1 - K2 Low Speed Contactor is energized by the low voltage control circuit.
- 2 - Compressor run windings 1 & 7 energized through K2-1 and K2-2.
- 3 - K2-3 and K2-4 close to energize the 4 pole start winding at terminal 8.
- 4 - K2-4 also powers a parallel start capacitor circuit through:

- C3 - start capacitor
- RT-2 - current limiting device
- K3 - N.C. potential relay contacts

- 5 - The start capacitor circuit is de-energized by potential relay when compressor comes up to speed. The contact opens at approximately 324V generated voltage from compressor windings (EMF Electro - Motive Force).
- 6 - K2-1 and K2-4 also energize the fan motor through the N.C. contacts (3 & 2) of the Defrost Control Switch.

B - COOLING MODE (HIGH SPEED)

24V Control Circuit High Speed(Figure 22)

- 1 - Thermostat demand on second stage (M2 terminal) energizes High Speed Relay (K4). The Reversing Valve (L1) remains energized.
- 2 - 24 volts is simultaneously fed through the Protection Module, Discharge Temperature Limit Switch (S4) and High Pressure Switch (S5).
- 3 - Timer Motor is energized through the timer contacts and N.O. K4-1 contacts. K4 is still energized from step 1.
- 4 - As the cam rotates, the timer switch controlling the Low Speed Contactor (K2) switches position to de-energize the low speed circuits. With K2 de-energized K2-5 returns to the closed position.
- 5 - After a time period, the cam will rotate further to switch position on the other contact, thus breaking power to the timer motor.
- 6 - The circuit is now complete through N.O. K4-2 contacts and K2-5 compressor interlock to energize the High Speed Contactor (K1).
- 7 - With K1 energized, the compressor interlock contacts K1-6 open to make sure the Low Speed Contactor (K2) cannot be energized.
- 8 - On 3 O units the Fan Relay (K3) remains energized through 1st stage cooling bulb, terminal "M" and "1".

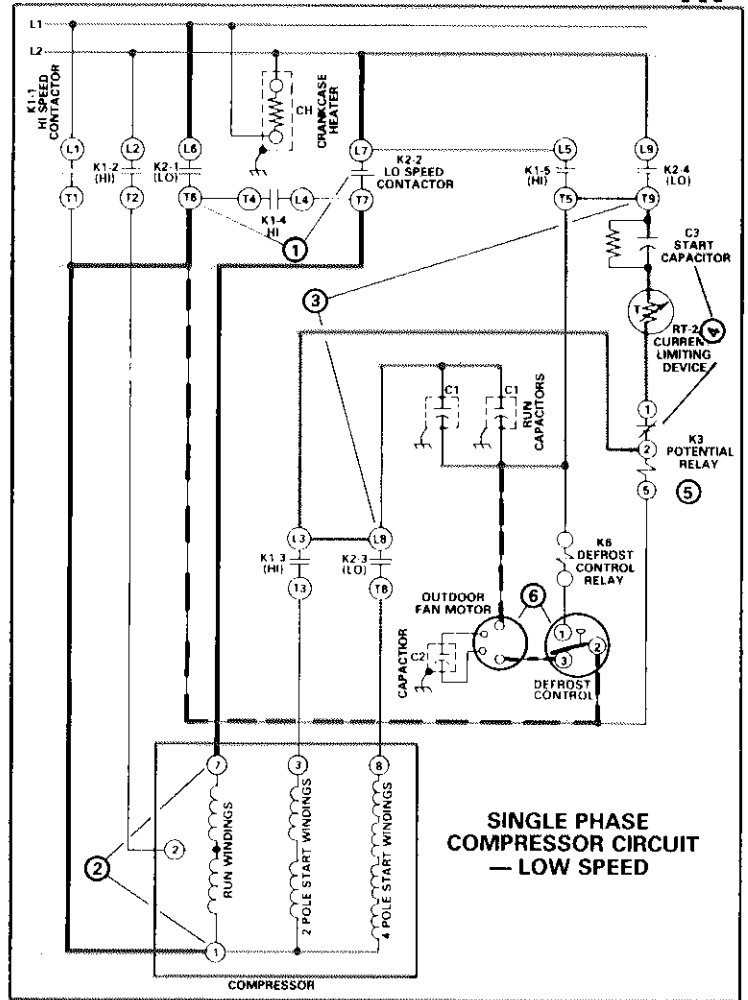

FIGURE 21

- 9 - When the second stage demand is satisfied, the High Speed Relay (K4) is de-energized which in turn de-energizes K1. It also energizes the timer motor through N.C. K4-2 contacts. This returns the timer switch to its normal position. If there is still a first stage demand, the timer motor will continue to drive thus repeating the 24V control circuit for low speed.

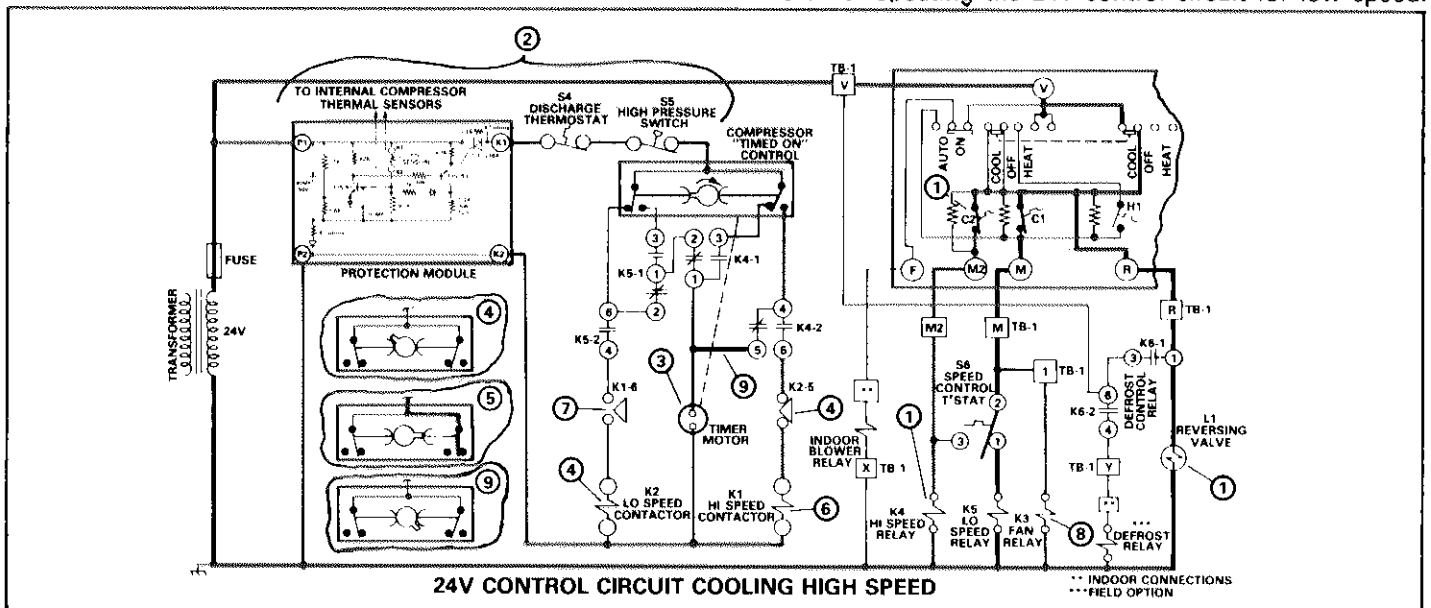

FIGURE 22

3 Ø Compressor Circuit - High Speed (Figure 23)

- 1 - K1-1 High Speed Compressor Contactor and K3-1 & K3-2 Fan Relay are closed by the low voltage control circuit.
- 2 - The fan motor is energized through N.O. K3 contacts and the N.C. terminals (2 & 3) of Defrost Control Switch. The

N.C. K3 contacts open to de-energize the crankcase heater.

- 3 - Compressor terminals 4, 5 and 6 are energized through contacts 1, 2 and 3.
- 4 - Contacts 4 and 5 also close to complete the parallel "Y" motor winding circuit through compressor terminals 1, 2 and 3.

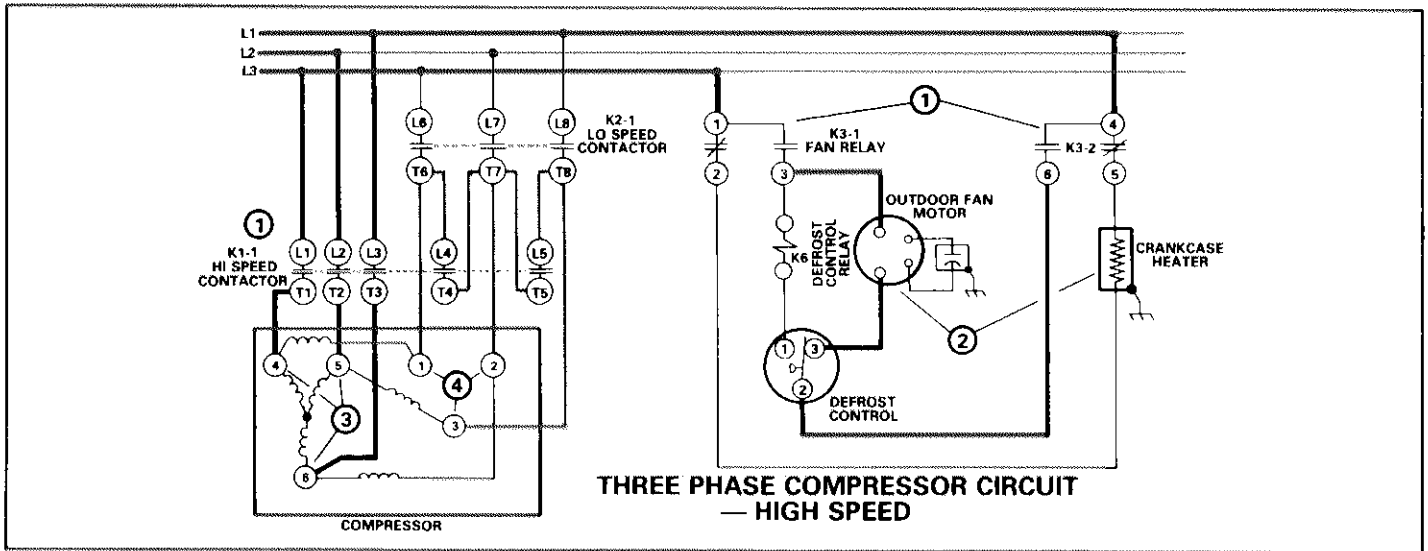

FIGURE 23

1 Ø Compressor Circuit - High Speed (Figure 24)

- 1 - K1 High Speed Contactor is energized by the low voltage control circuit.
- 2 - Compressor run windings 1 & 2 energized through K1-1 and K1-2. K1-1 also powers run winding 7 through K1-4.
- 3 - K1-5 and K1-3 close to energize the 2 pole start winding at terminal 3.
- 4 - K1-5 also powers a parallel start capacitor circuit through:

- C3 - start capacitor
- RT-2 - current limiting device
- K3 - N.C. potential relay contacts

- 5 - The start capacitor circuit is de-energized by potential relay when compressor comes up to speed.
- 6 - K1-1 and K1-5 also energize the fan motor through the N.C. contacts (3 & 2) of the Defrost Control Switch.

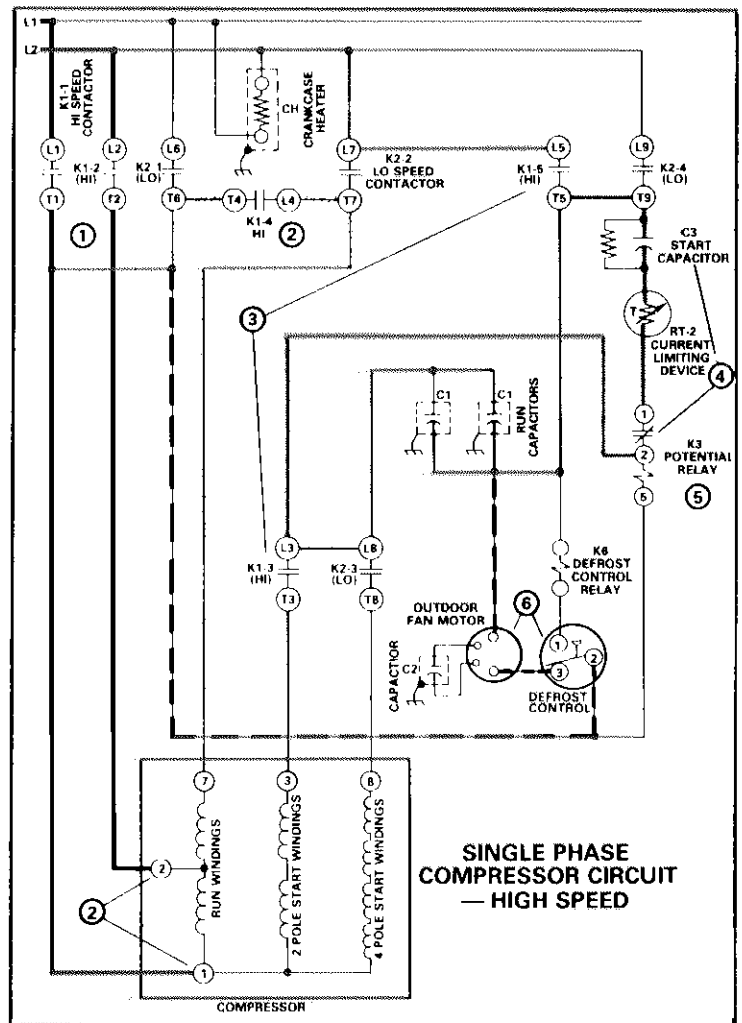

FIGURE 24

C - HEATING MODE (LOW SPEED)

24V Control Circuit Heating Low Speed (Figure 25)

- 1 - Thermostat powered through V terminal.
- With the thermostat in the heating mode, the reversing valve (L1) will remain de-energized.
- 2 - A heating demand closes 1st stage heating bulb and energizes Low Speed Relay (K5) through "M" and terminals 2 & 1 of Outdoor Ambient Control Thermostat (S6).
- 3 - 24 volts is simultaneously fed through the Protection Module, Discharge Temperature Limit Switch (S4) and High Pressure Switch (S5).

- 4 - Timer Motor is energized through N.C. timer switch, N.O. K5-1 contacts (energized at step 2) and N.C. K4-1 contacts.
- 5 - After a time period, the cam repositions the timer switch to break power to timer motor.
- 6 - Low Speed Contactor (K2) is energized through N.O. K5-2 contacts and the N.C. K1-6 compressor interlock.
- 7 - With K2 energized, the compressor interlock contacts K2-5 open to make sure the High Speed Contactor (K1) cannot be energized.
- 8 - On 3Ø units the Fan Relay (K3) is also energized by first stage heat through terminal "M" and "1".

NOTE - Single speed compressor operation is the same as dictated in Figures 20 and 21.

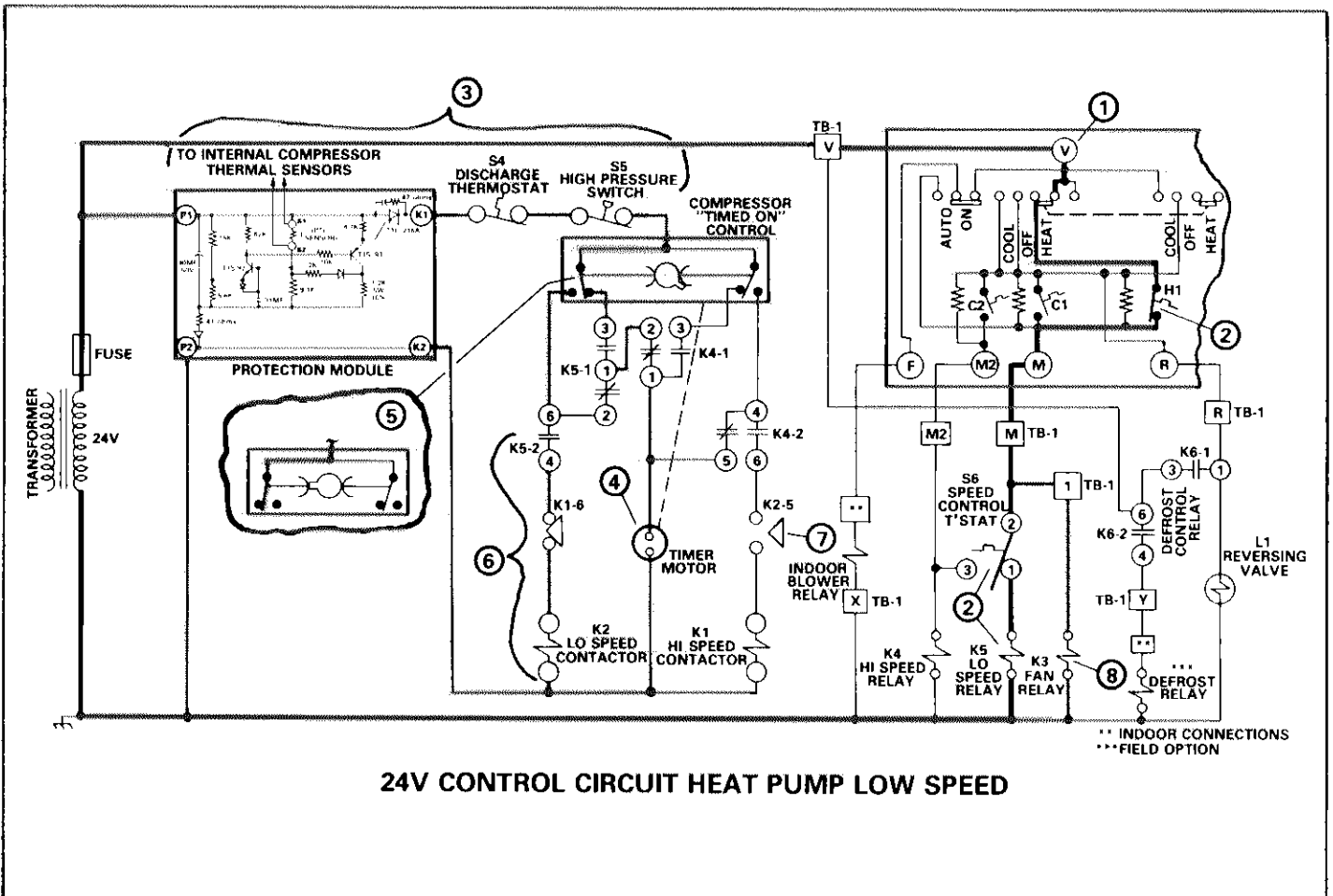

FIGURE 25

D-HEATING MODE (HIGH SPEED)

24V Control Circuit Heating High Speed (Figure 26)

- 1 - Thermostat first stage heating bulb remains closed. At an ambient temperature drop below 45°F the Outdoor Ambient Speed Control Thermostat (S6) switches position to de-energize K5 and energize the High Speed Relay (K4).
- 2 - The compressor timed-on control is still being powered through the Protection Module, Discharge Temperature Limit Switch (S4) and High Pressure Switch (S5).
- 3 - With K5 de-energized, K5-2 opens to also de-energize the Low Speed Contactor. K2-5 returns to the closed position.
- 4 - With K4 energized, the timer motor is powered through K4-1. This moves the cam.
- 5 - After a time period, the cam will rotate to switch position on the contacts, thus breaking power to the timer motor.
- 6 - The circuit is now complete through N.O. K4-2 contacts and K2-5 compressor interlock to energize the High Speed Contactor (K1).

- 7 - With K1 energized, the compressor interlock contacts K1-6 open to make sure the Low Speed contactor (K2) cannot be energized.
- 8 - On 3 Ø units the Fan Relay (K3) remains energized through 1st stage heat bulb, terminal "M" and "1".
- 9 - If further heat is needed the second stage heat bulb closes to bring on the auxilliary heat.
- 10 - If the thermostat is satisfied K4 is de-energized and the timer motor is powered through the N.C. K4-2 contacts. Upon the next heating demand, the cam must drive a complete revolution before K1 can again be energized.
- 11 - As the ambient temperature rises above 50°F, S6 again switches position to power K5 and de-energize K4. The Compressor Timed-On Control runs through another cycle as explained in Figure 25.

NOTE - High speed compressor operation is the same as dictated in Figures 23 and 24.

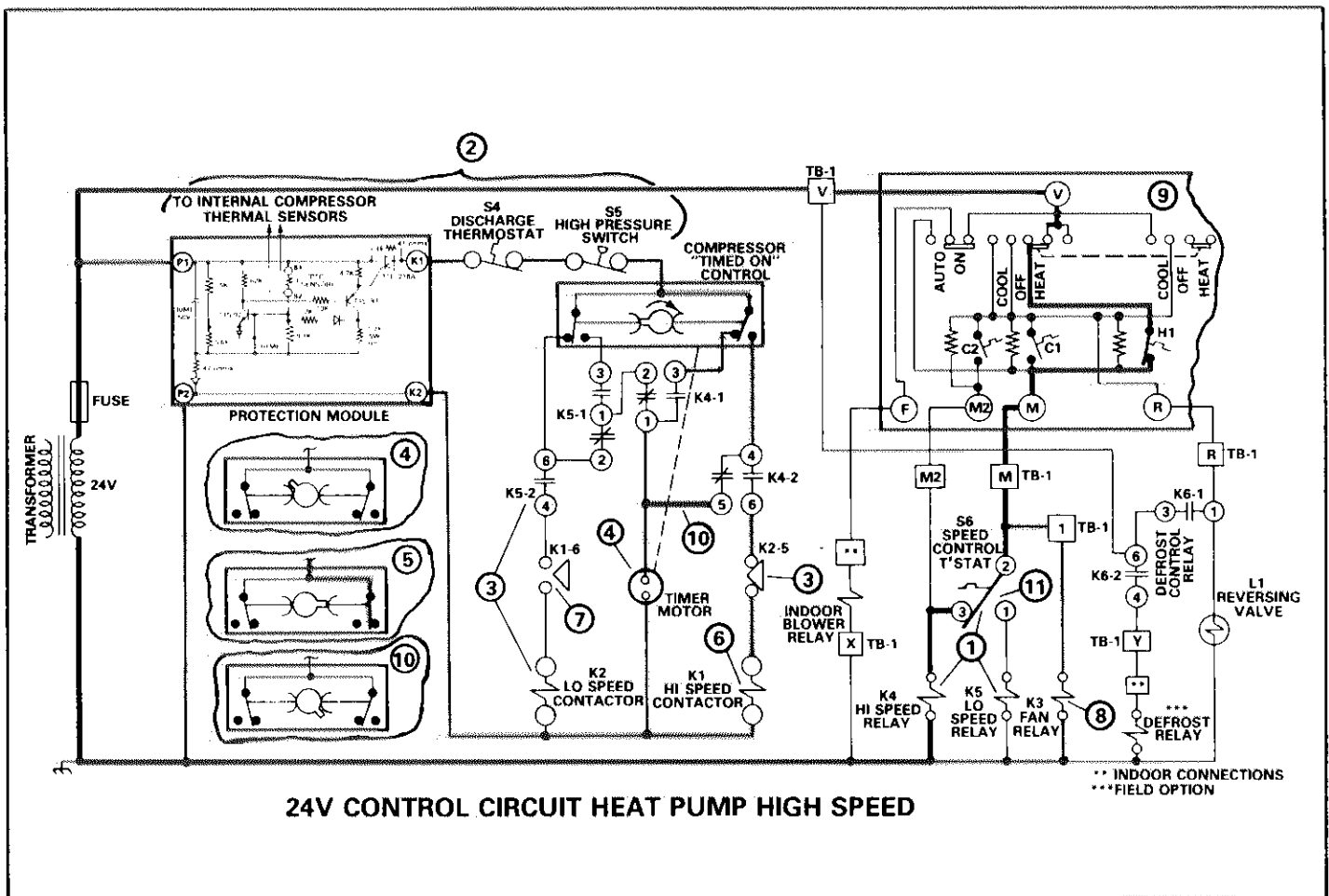

FIGURE 26

VII - DEFROST CYCLE

Figure 27 explains basic operation. The defrost control is a pressure operated single-pole double-throw switch. Terminals 2 and 3 are normally closed as ice builds up restricting the air-flow, the pressure difference between point A and point B increases and the switch is activated breaking contacts 2 to 3 and making 2 to 1. Figure 28 illustrates schematically the sequence of operation.

1 - This de-energizes the outdoor fan motor and powers the Defrost Control Relay (K6).

- 2 - K6-1 closes its contacts to energize the reversing valve (L1).
- 3 - K6-2 also closes its contacts to energize the defrost relay (if used). The defrost relay provides auxilliary heat to compensate for the temporary cooling during the defrost cycle.
- 4 - At the end of the defrost cycle, the Defrost Control Switch returns to its normal position to power the fan motor and to de-energize K6.

NOTE - The single phase unit is shown. The outdoor fan motor and defrost circuit are powered by the Fan Relay.

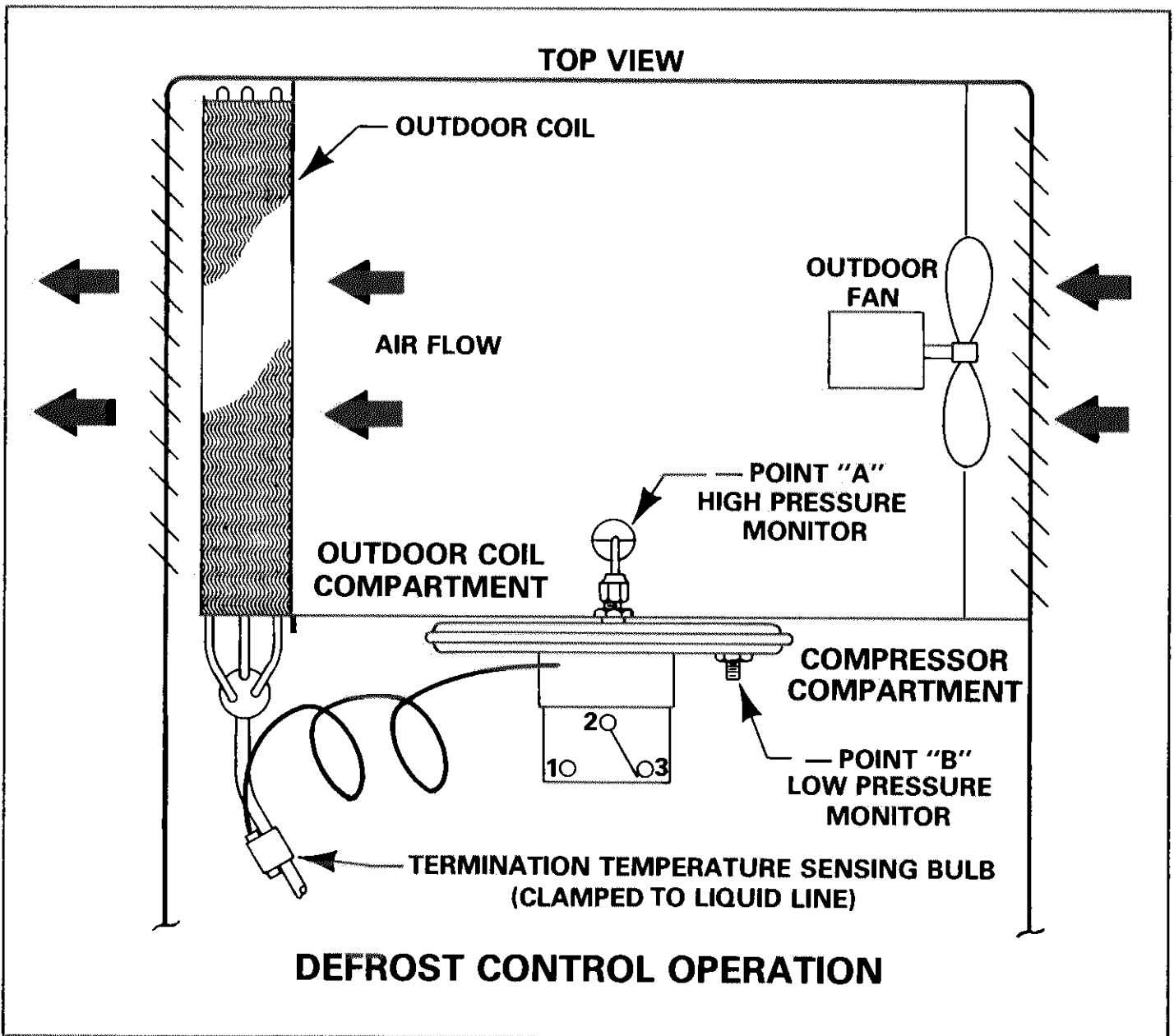

FIGURE 27

HP11 DEFROST CYCLE CONTROL CIRCUIT

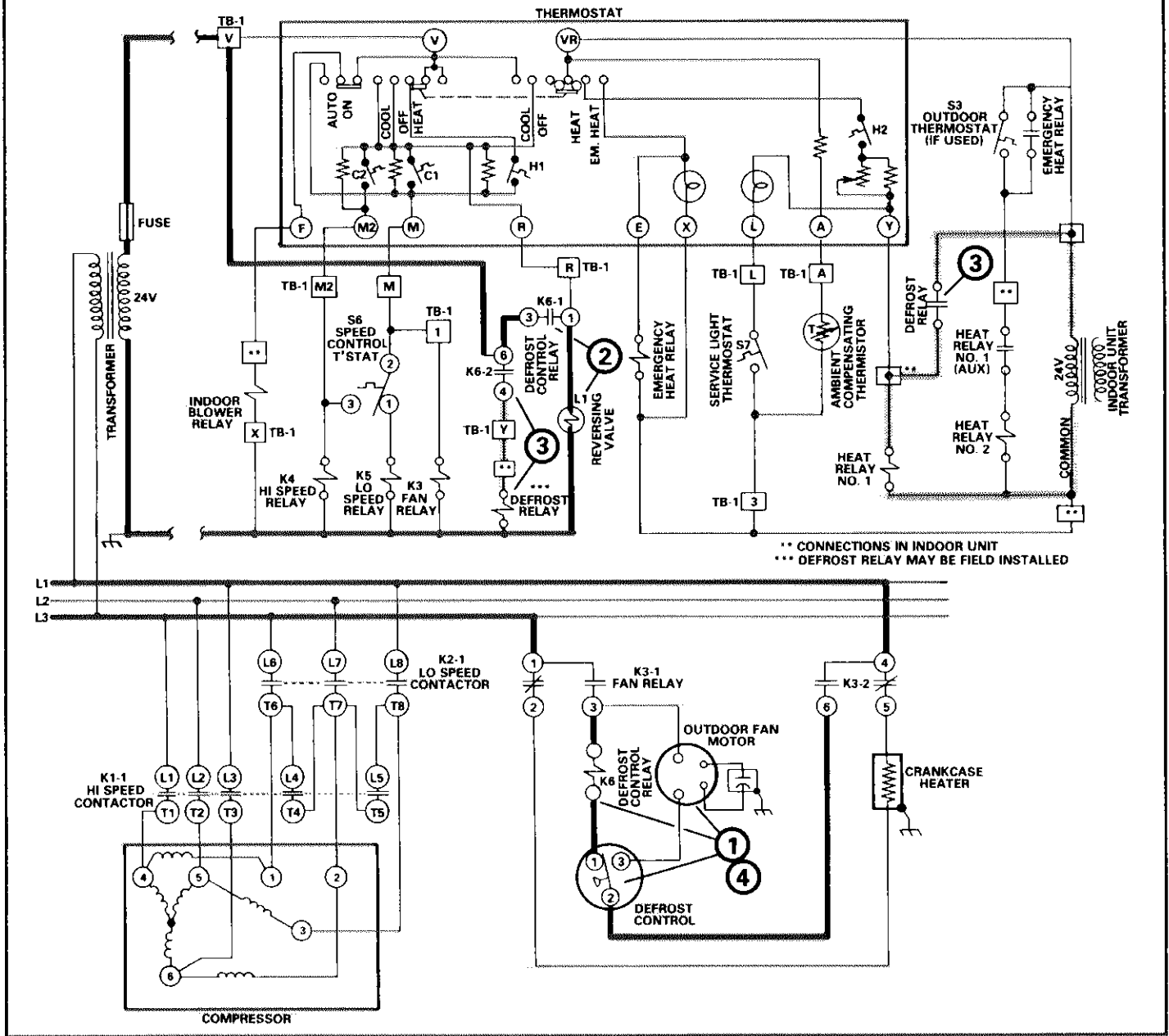

FIGURE 28

VIII - TROUBLESHOOTING

Other than the timed on control and switching required for speed changes, the other HP11 components are standard and should not present particular problems.

When servicing an HP11 it is necessary to know what position the time delay relays are in. The simplest method is to check for power at relays K4 and K5. Check from the ground side of the transformer to terminals 6 and 3 on K5, and terminals 3 and 4 on K4. Check terminal 1 on K4 to see if the timer motor should be energized. Power at terminal 4 on K5 indicates that the low speed contactor (K2) should be made. Power at terminal 6 on K4 indicates that the high speed contactor (K1) should be energized.

During the heating cycle the Speed Control Thermostat (S6) determines compressor speed. This control can cause a condition, while not creating a problem, could raise customer questions. If the unit is operating just below the 45°F temperature and it goes into defrost, the heat from the compressor and the steam from the outdoor coil can be enough to warm the control and switch it back to low speed (the fan is not operating). There is a timed off cycle and the unit then completes its defrost in low speed. The defrost cycle takes longer, but it will clear itself. Now when the defrost cycle terminates, the unit starts in low speed. As soon as the fan starts, S6 cools and switches back to high speed after a timed on cycle in between.